

VT-EH10 / HMT8

INDOOR/OUTDOOR CAMERA ENCLOSURE & MOUNT



VT-EH10:

- ▶ HEAVY-DUTY ALUMINUM CONSTRUCTION
- ▶ ADJUSTABLE CAMERA TRAY
- ▶ LOCKABLE REAR LATCH
- ▶ TOP SWINGS OPEN FOR EASE IN SERVICING

VT-HMT8:

- ▶ HEAVY-DUTY CONSTRUCTION
- ▶ TAMPER RESISTANT ALLEN SCREWS
- ▶ ADJUSTABLE P/T HEAD

The VT-EH10 is an economical environmental enclosure with rugged construction and attractive design. A forward hinged cover enables easy access to camera for installation and servicing. 24 vac heater and blower kits are available to protect your camera from the harshest environment.

Specifications	VT-EH10	VT-HMT8
Construction	Aluminum Body, Plastic Front & Rear Caps	Aluminum
Max Camera / Lens Length	11 Inches	N/A
Camera Access	Hinged Forward	N/A
Dimensions	(With Visor)	8.8" L x 2.9" W x 4.5" H
Maximum Adjustment	N/A	360° Pan / 90° Tilt
Hole Pattern	N/A	1.6" Horizontal on Center / 3.3" Vertical on Center

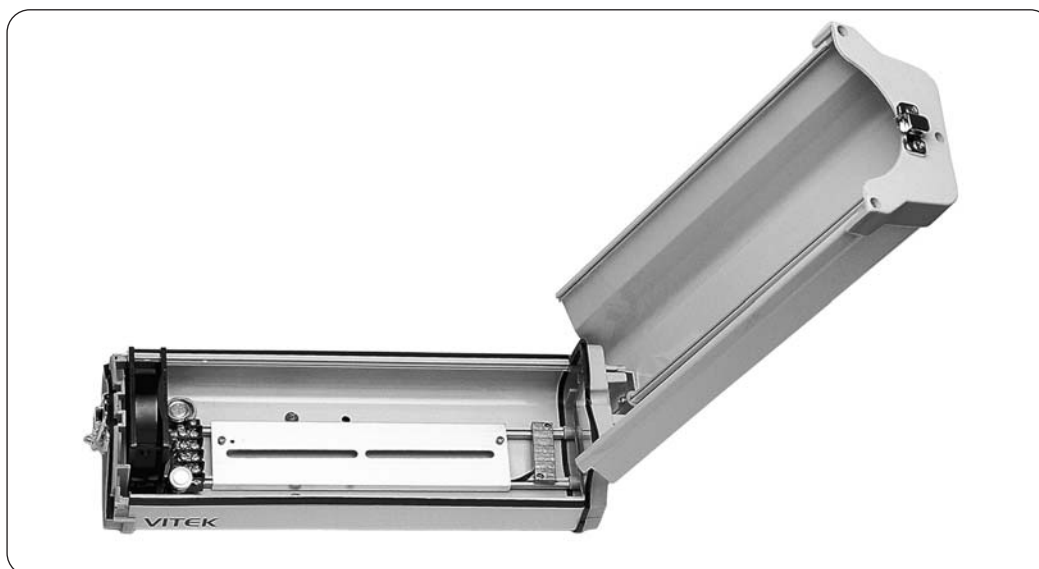

Shown above with optional 24 vac Heater and Blower Kit.
 Order model VT-EH 10 /BH 24. Heater and Blower
 Kit also sold separately as VT-B 24 and VT-H 24.